

RAFE B. EVANS  
Vice President

## WANTED: HIGH END RETAILER

### Space Facts

<i>Space Address</i>	50 W 44 <sup>th</sup> Street, between 5 <sup>th</sup> & 6 <sup>th</sup> Avenue
<i>Neighborhood</i>	Midtown
<i>Approximate Size</i>	1,155 sf
<i>Approximate Frontage</i>	27 feet
<i>Rent</i>	REASONABLE RENT FOR PRESTIGE TENANT

### Note

- High ceilings, new front
- Good for boutique, gifts, wine bar, etc.
- On busy "Club Row" near major attractions and transportation hubs
- Note: full commission to procuring broker
- No cooking or food, please

### Contact

**Rafe B. Evans**

**212-712-6186**

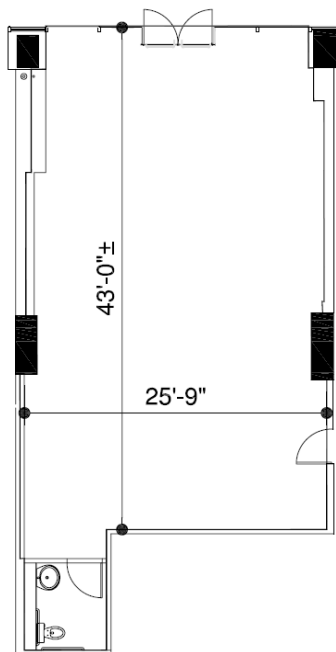

ALL INFORMATION IS SUBJECT TO, ERRORS, OMISSIONS, CHANGE, OR WITHDRAWAL WITHOUT NOTICE. Dimensions are approximate. One commission is payable in accordance with our rate schedule to procuring broker executing our brokerage agreement, provided that a lease is fully consummated as described in said agreement. Our commission rate schedule is available upon request.

